

FIGURE 1-1 Ideal diode: (a) symbol; (b) characteristics.

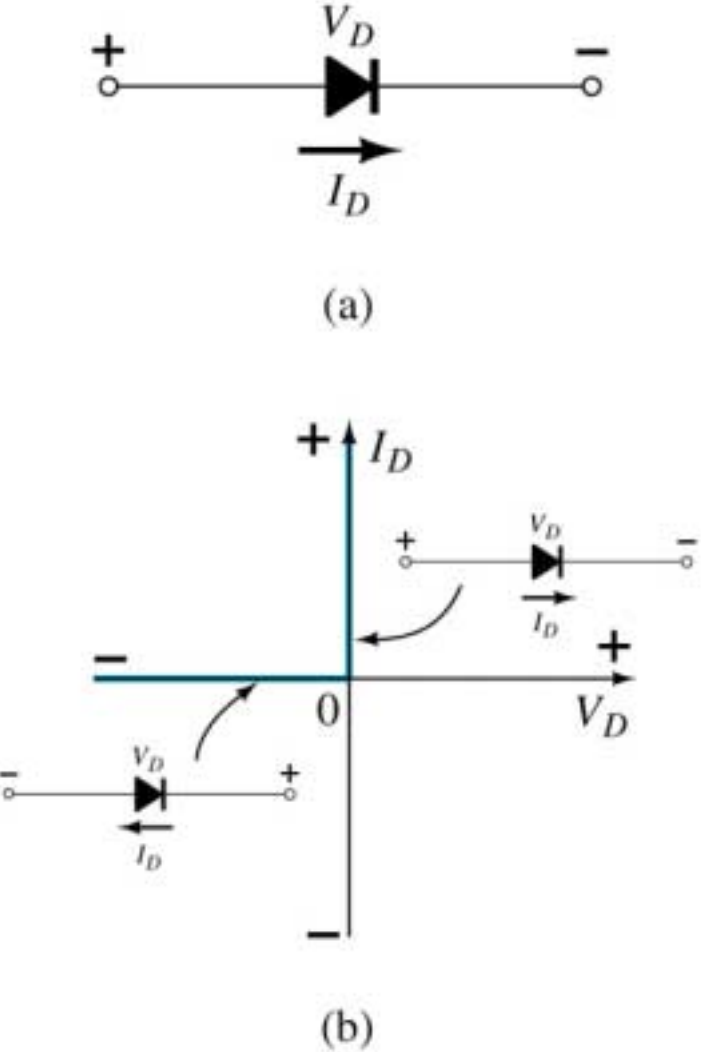

FIGURE 1-2 (a) Conduction and (b) nonconduction states of the ideal diode as determined by the applied bias.

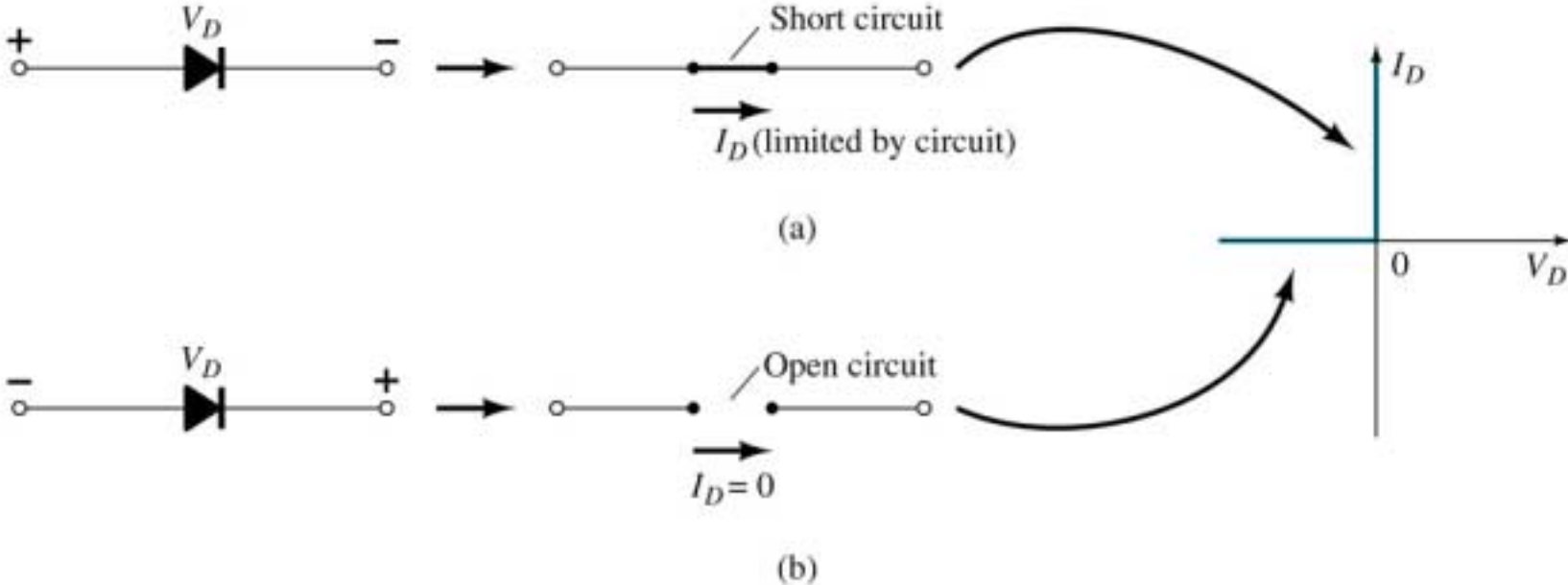

FIGURE 1-6 Atomic structure: (a) germanium; (b) silicon.

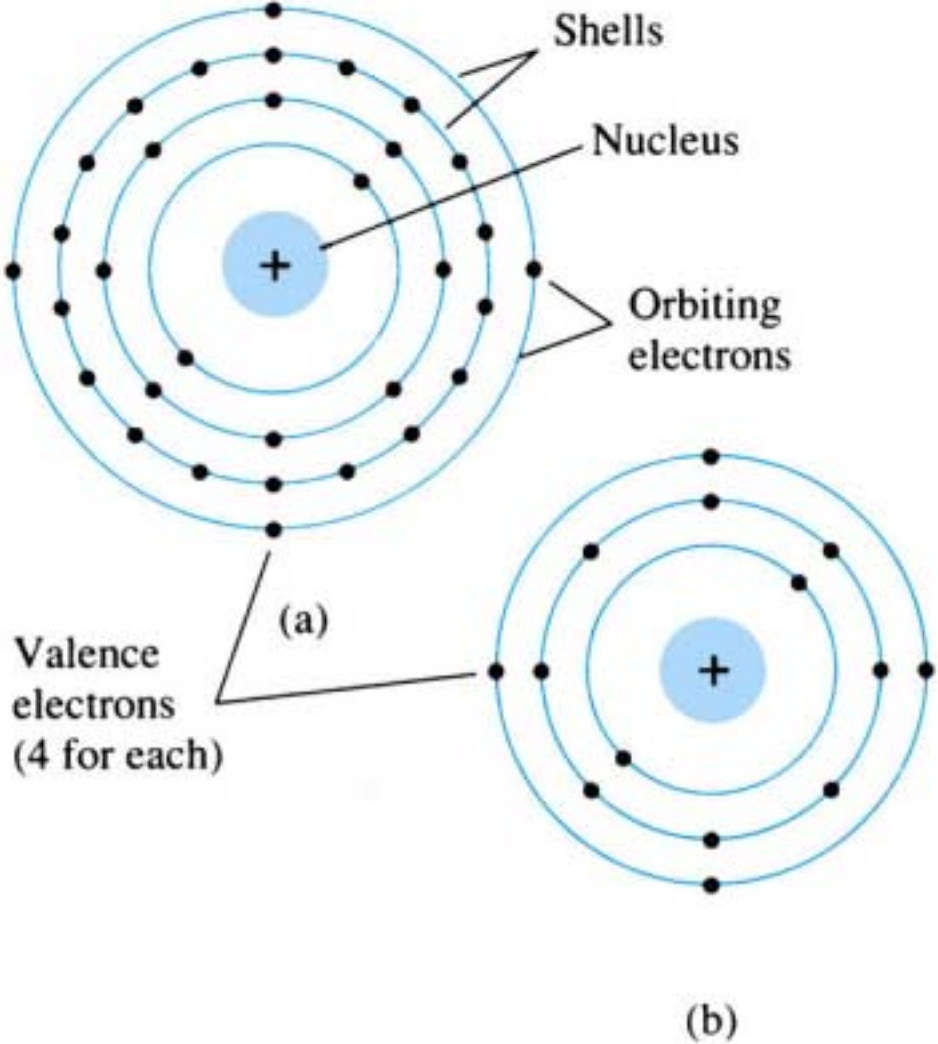

FIGURE 1-7 Covalent bonding of the silicon atom.

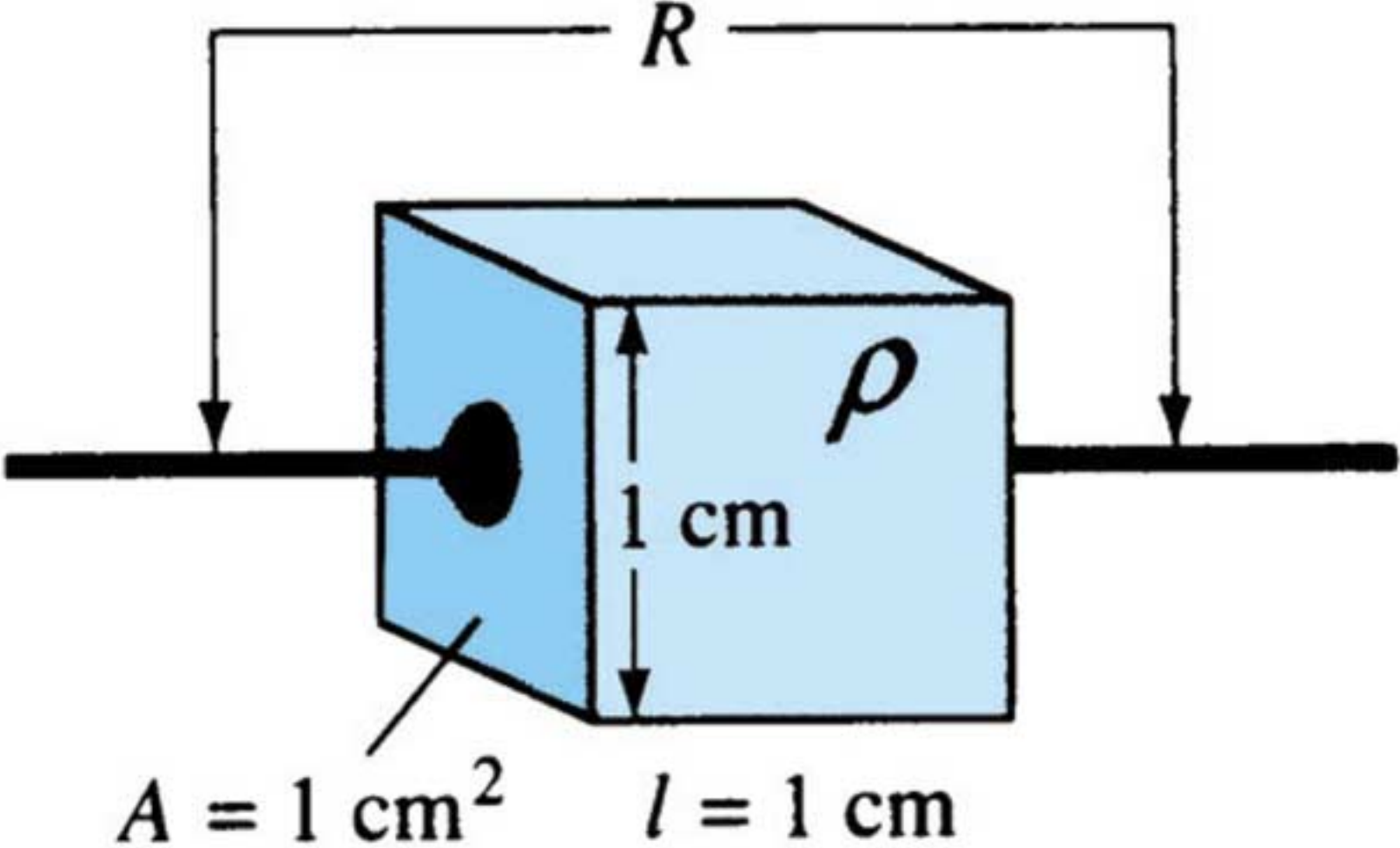
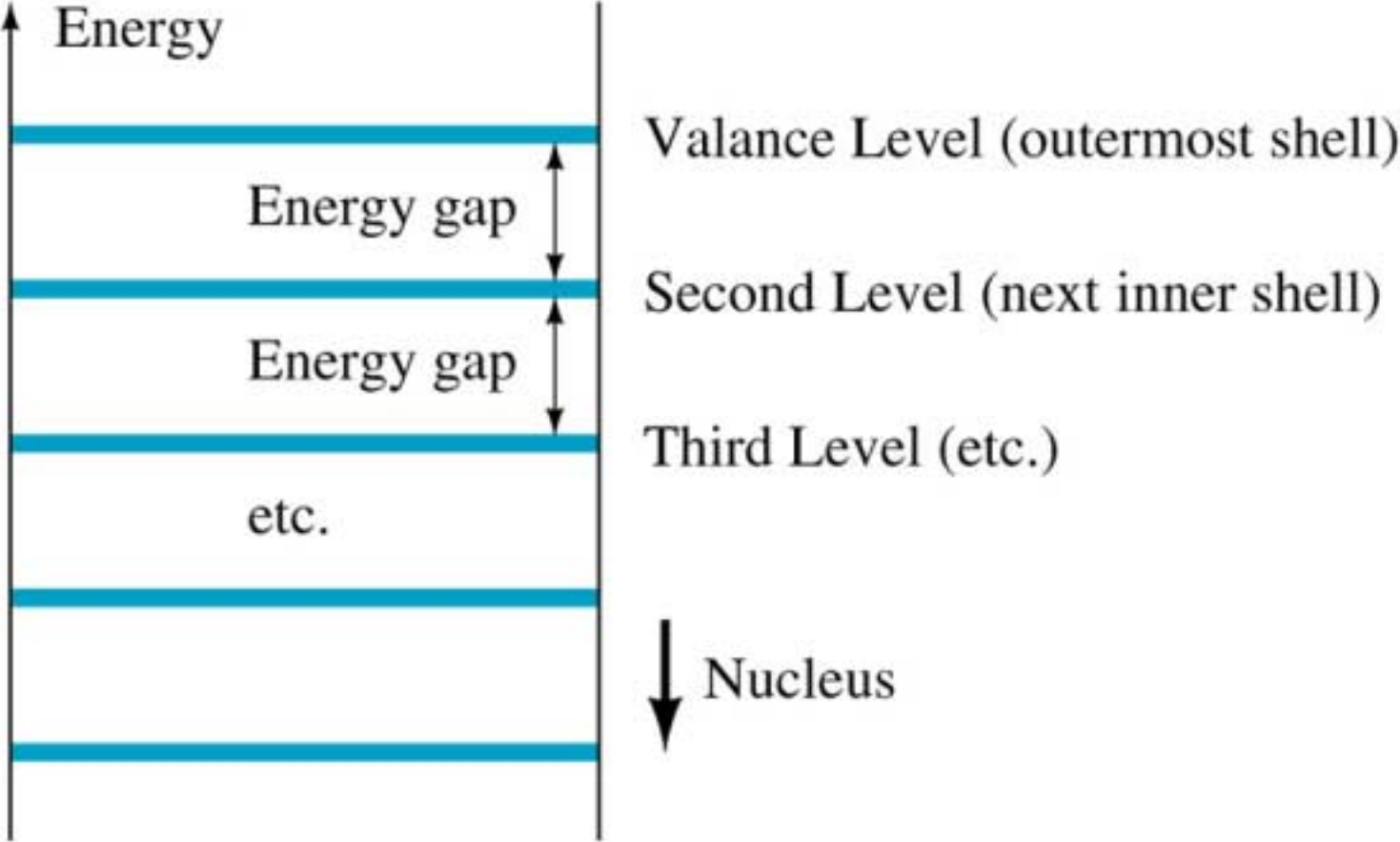
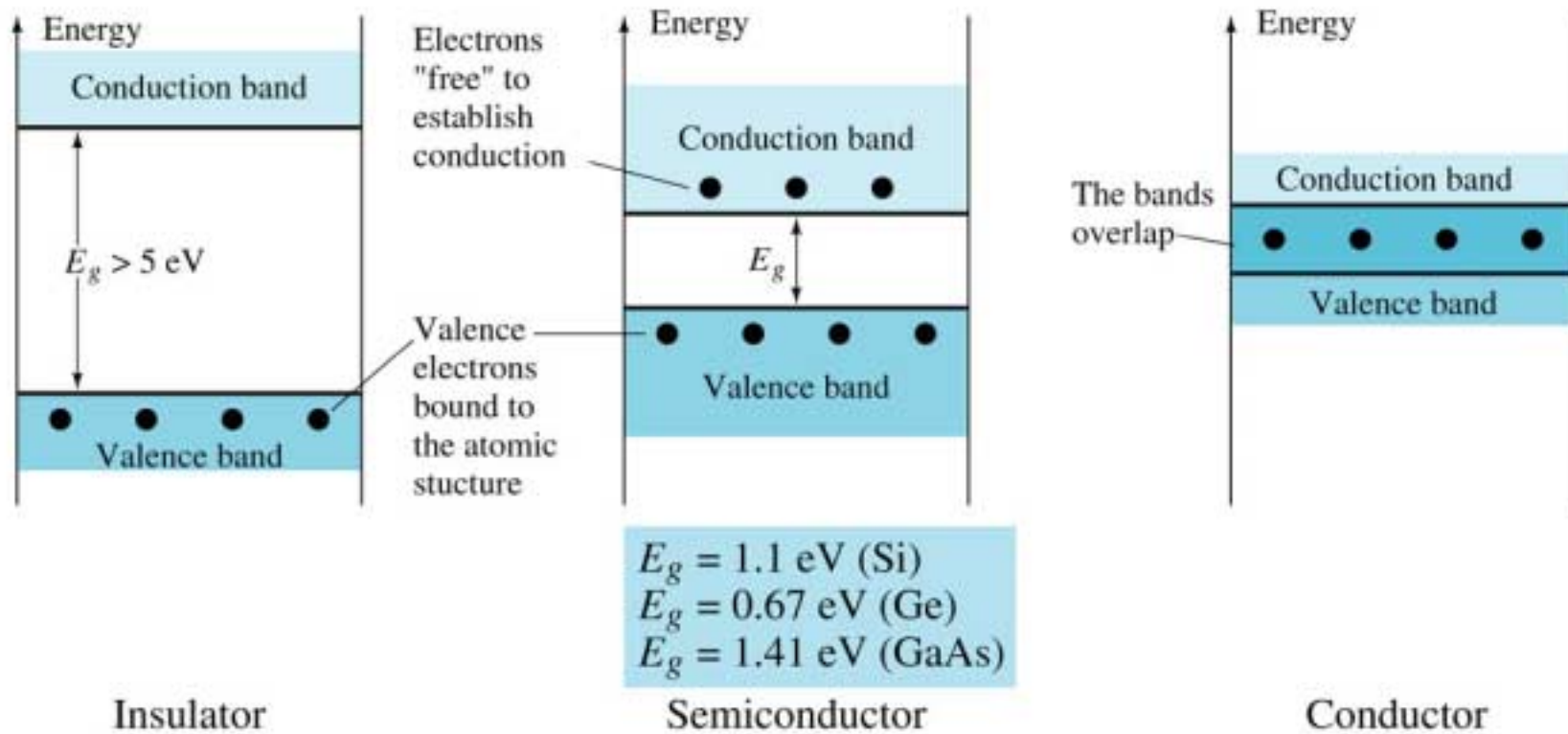

FIGURE 1-8a Energy levels: discrete levels in isolated atomic structures.



(a)

FIGURE 1-8b Energy levels: conduction and valence bands of an insulator; semiconductor; and conductor.



(b)

FIGURE 1-9 Antimony impurity in n-type material.

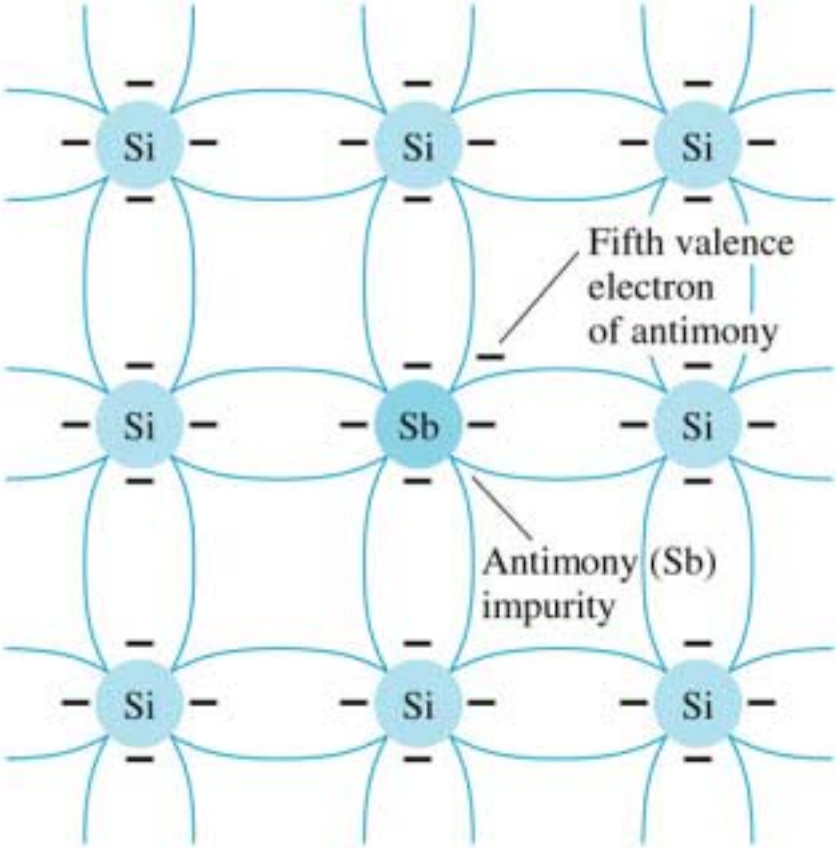

FIGURE 1-10 Effect of donor impurities on the energy band structure.

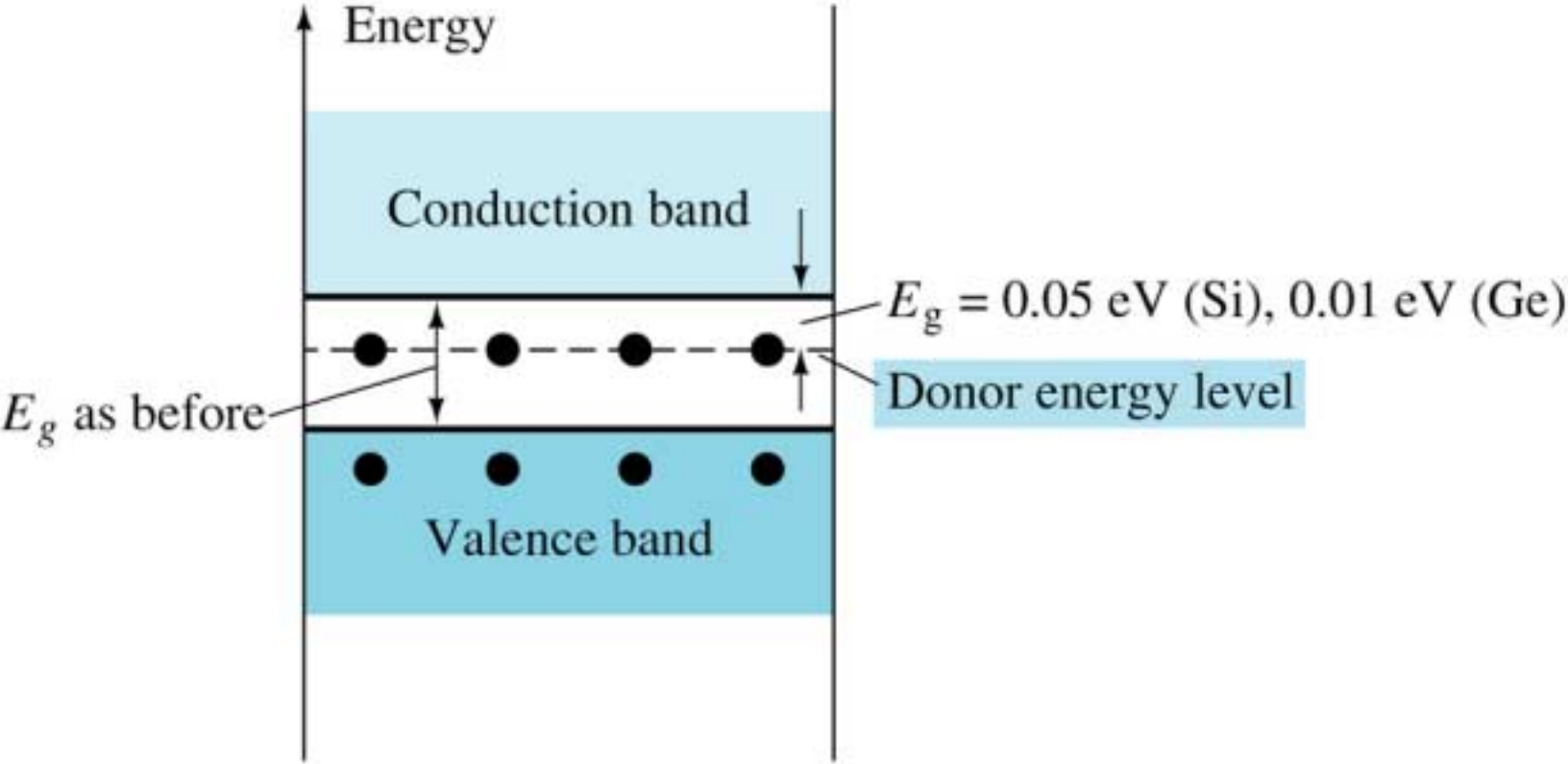

FIGURE 1-11 Boron impurity in *p*-type material.

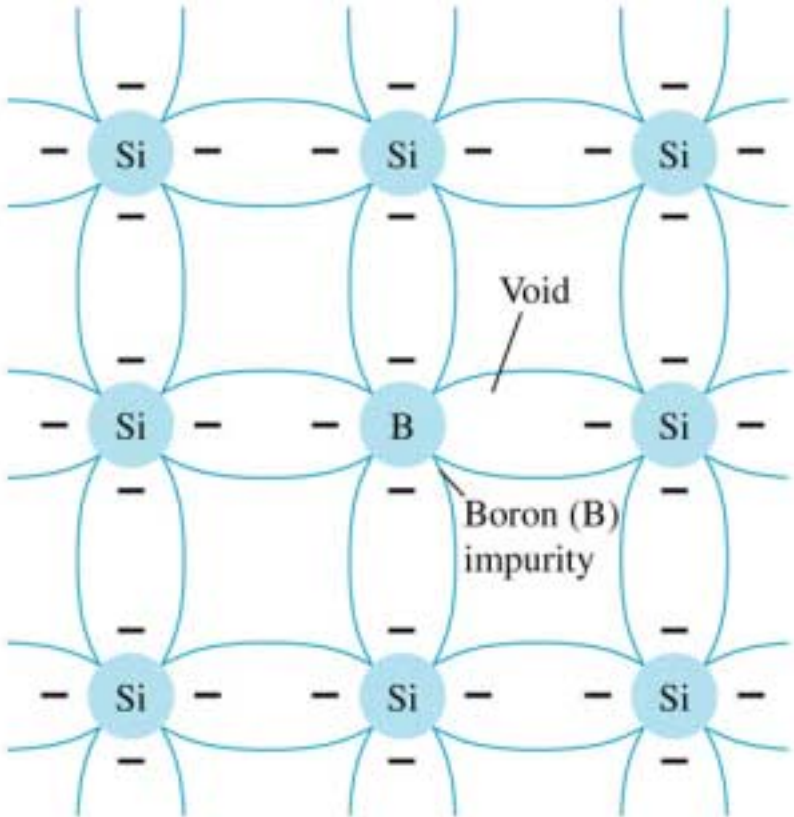

FIGURE 1-12 Electron versus hole flow.

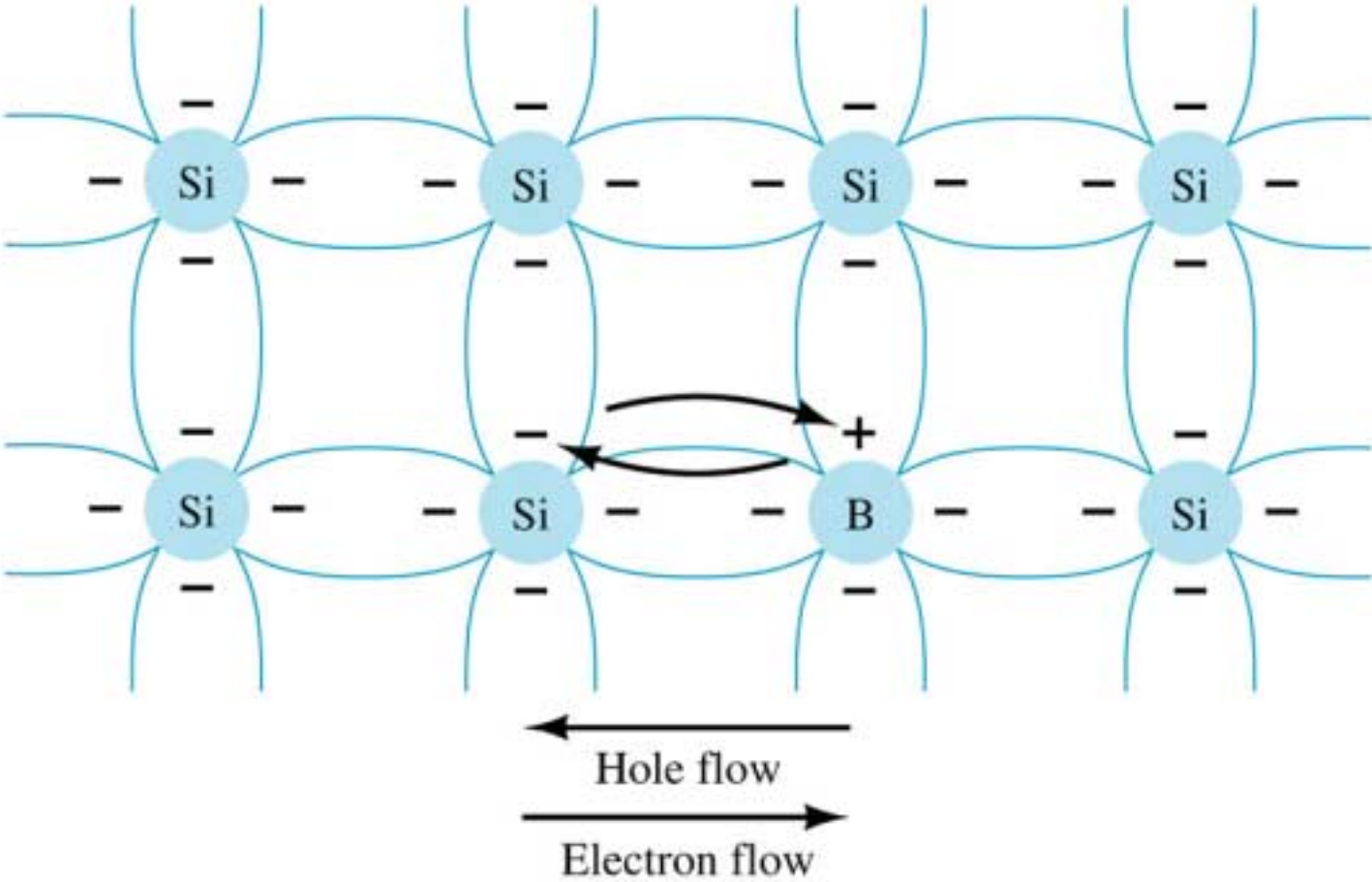

FIGURE 1-13 (a) *n*-type material; (b) *p*-type material.

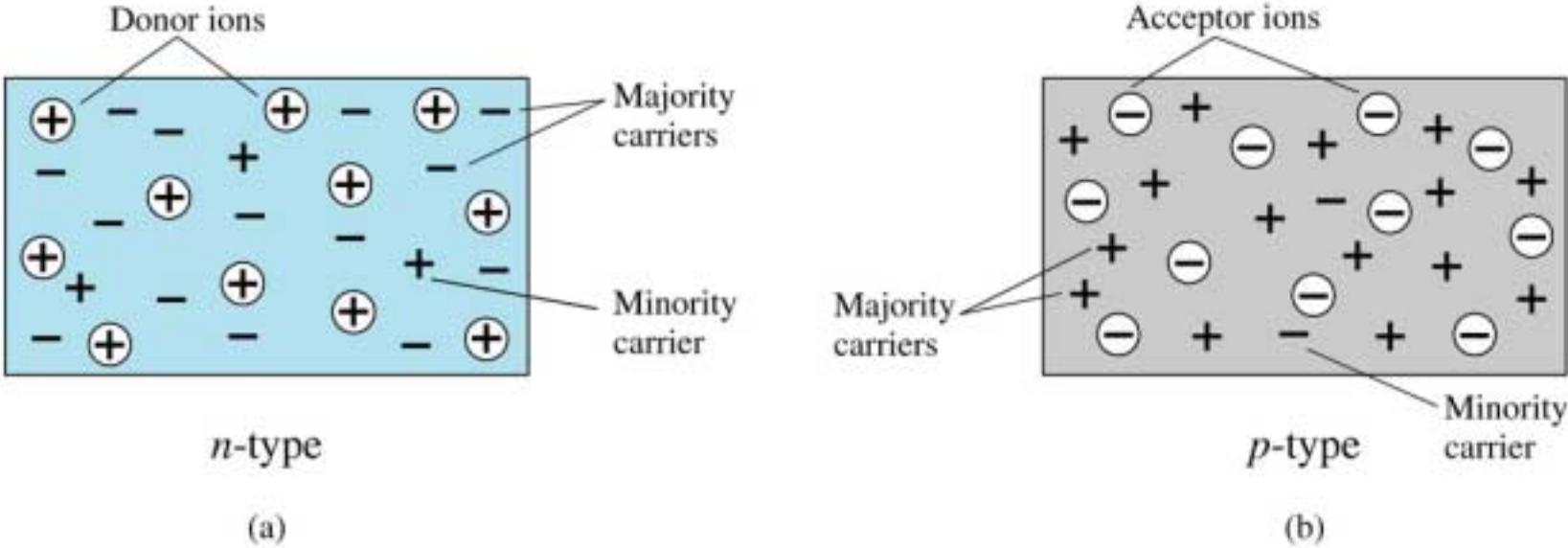

FIGURE 1-14 *p-n* junction with no external bias.

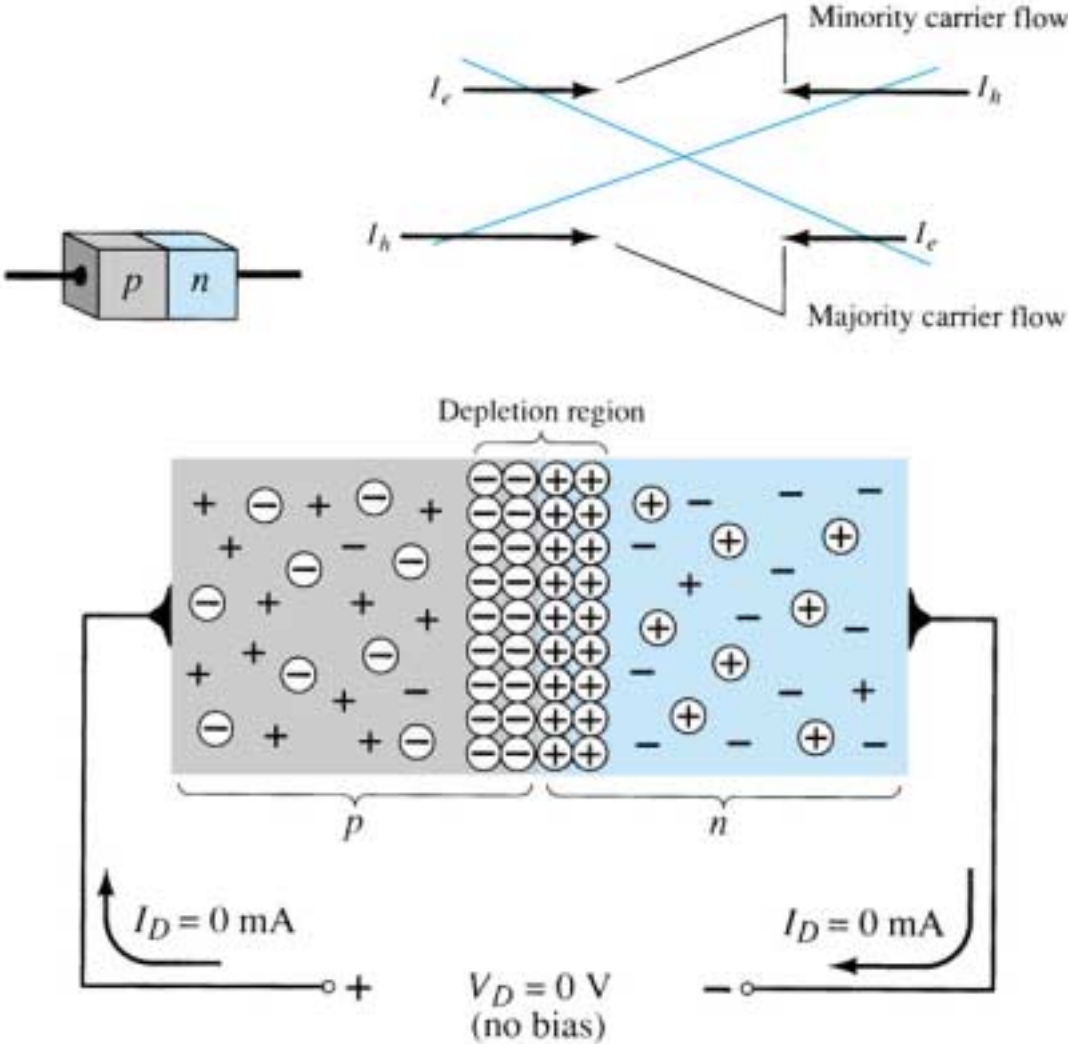

FIGURE 1-15 No-bias conditions for a semiconductor diode.

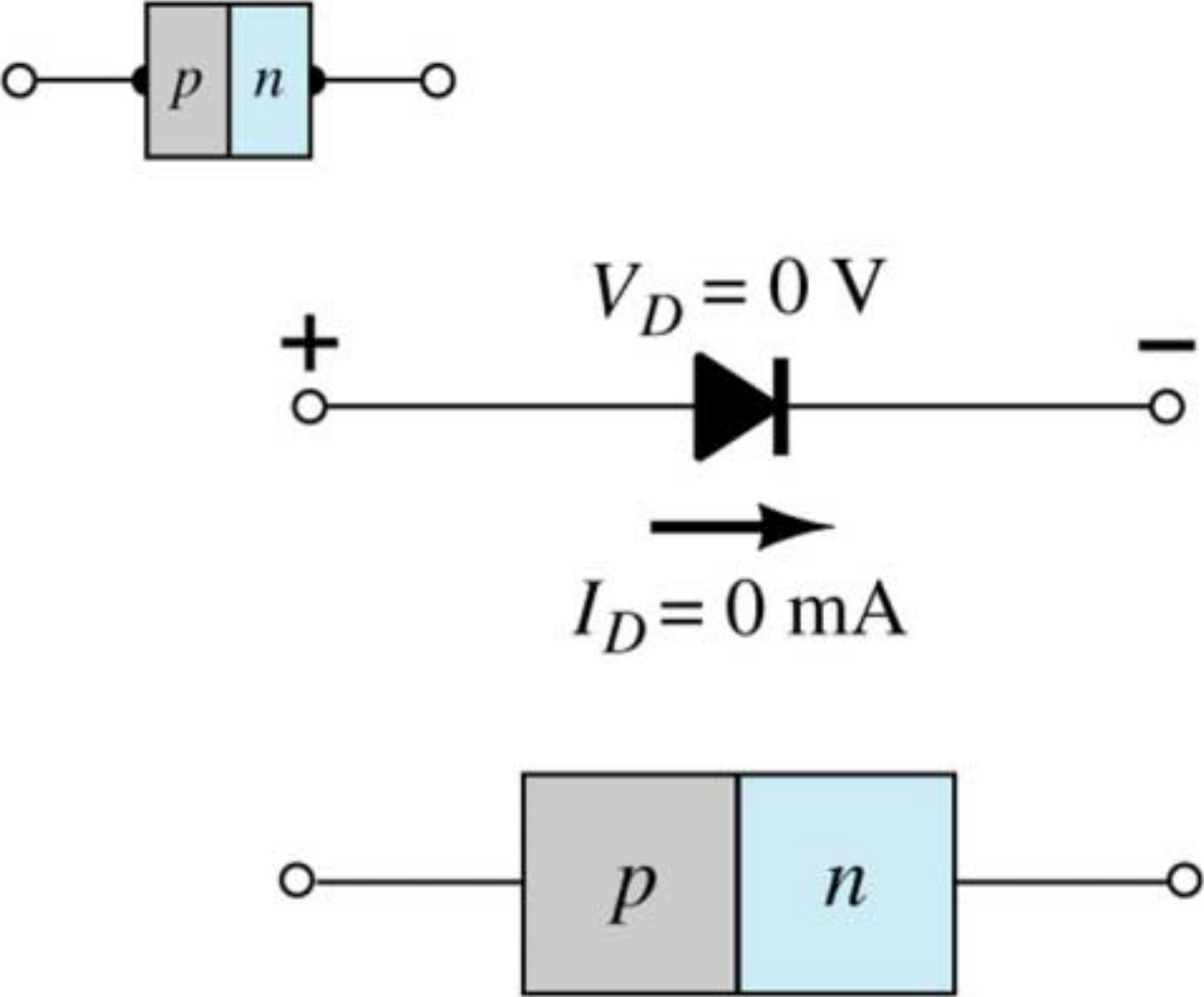

FIGURE 1-16 Reverse-biased *p-n* junction.

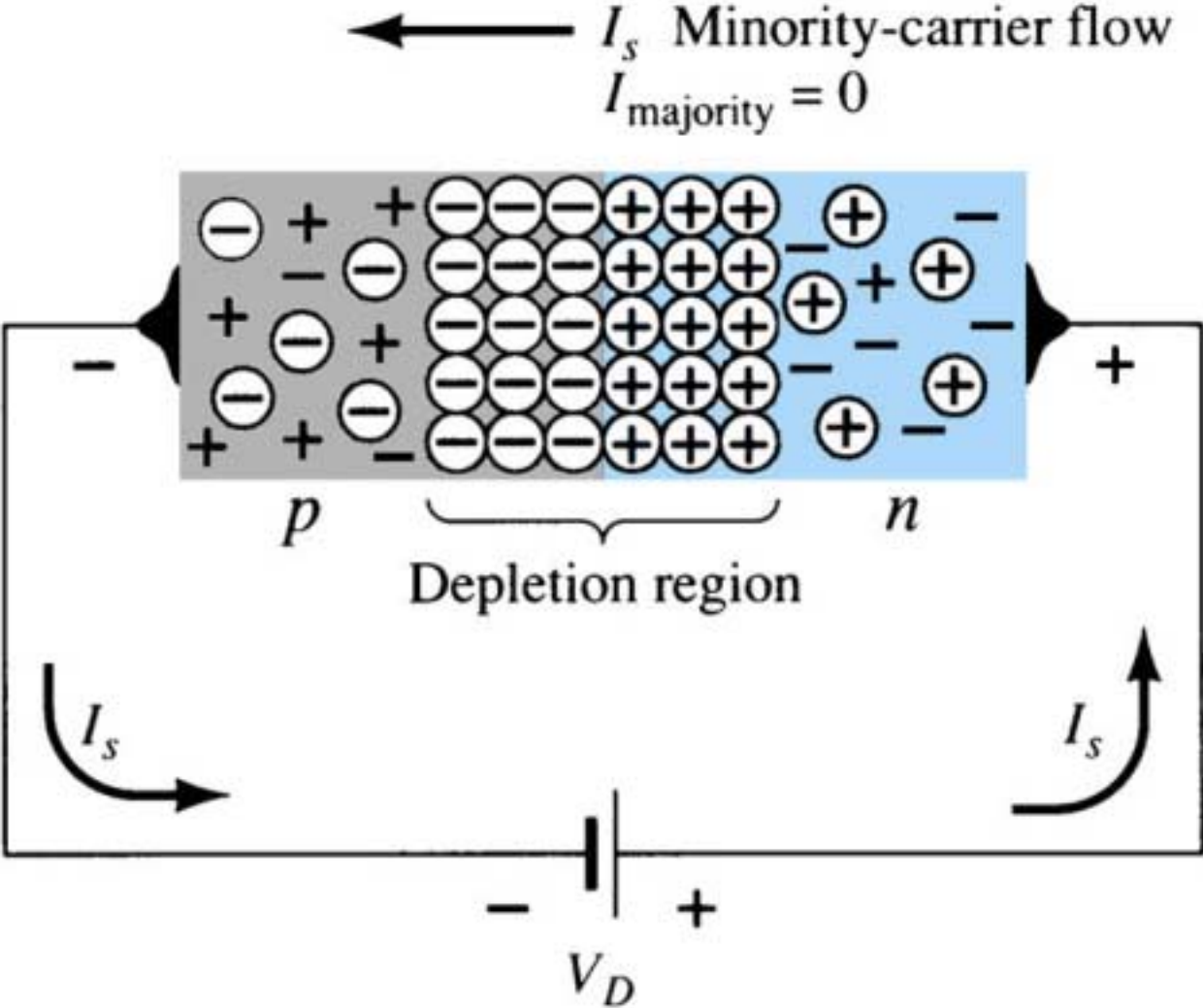

FIGURE 1-17 Reverse-bias conditions for a semiconductor diode.

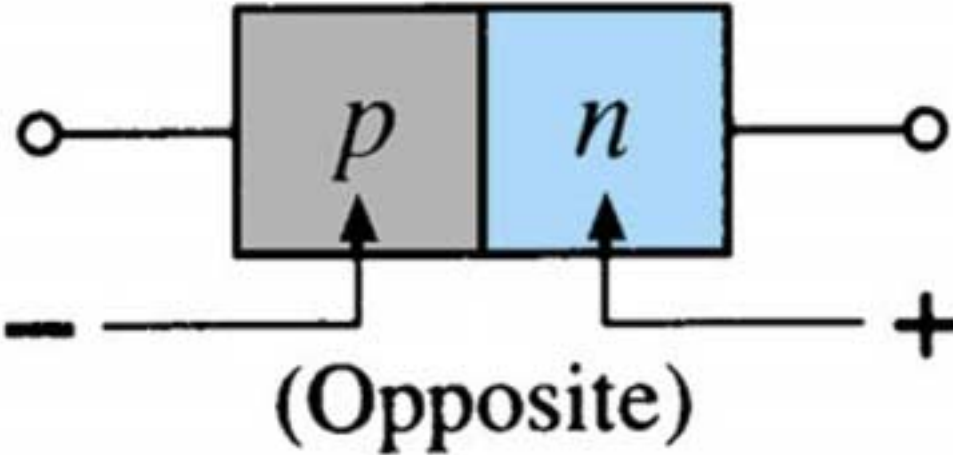
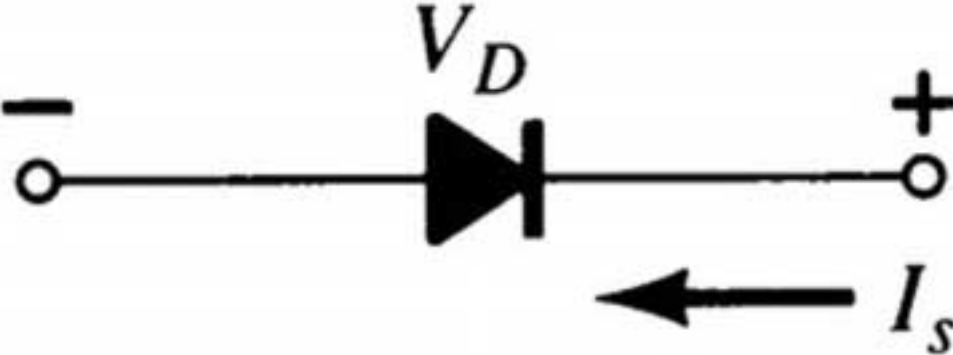

FIGURE 1-18 Forward-biased *p-n* junction.

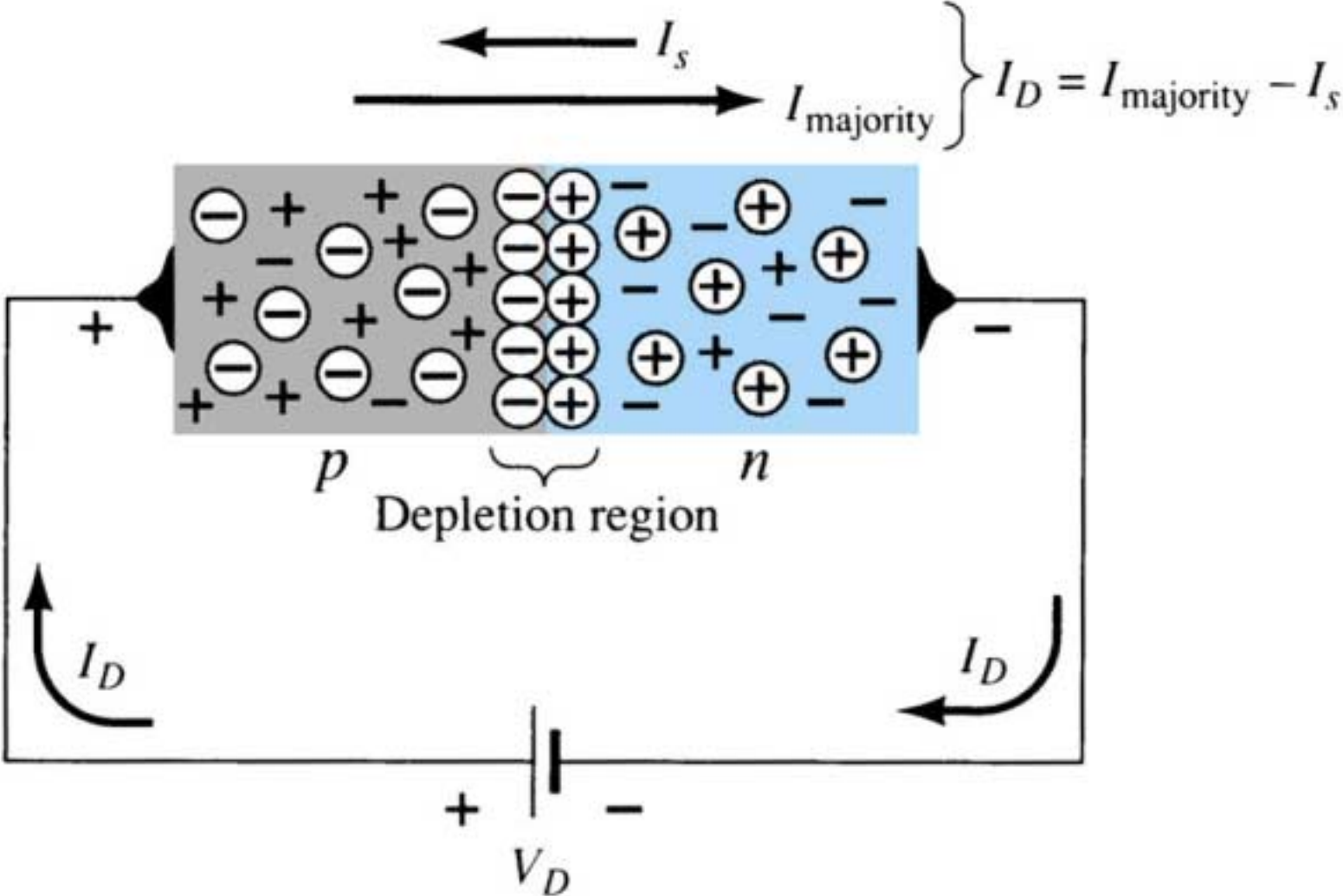

FIGURE 1-19 Silicon semiconductor diode characteristics.

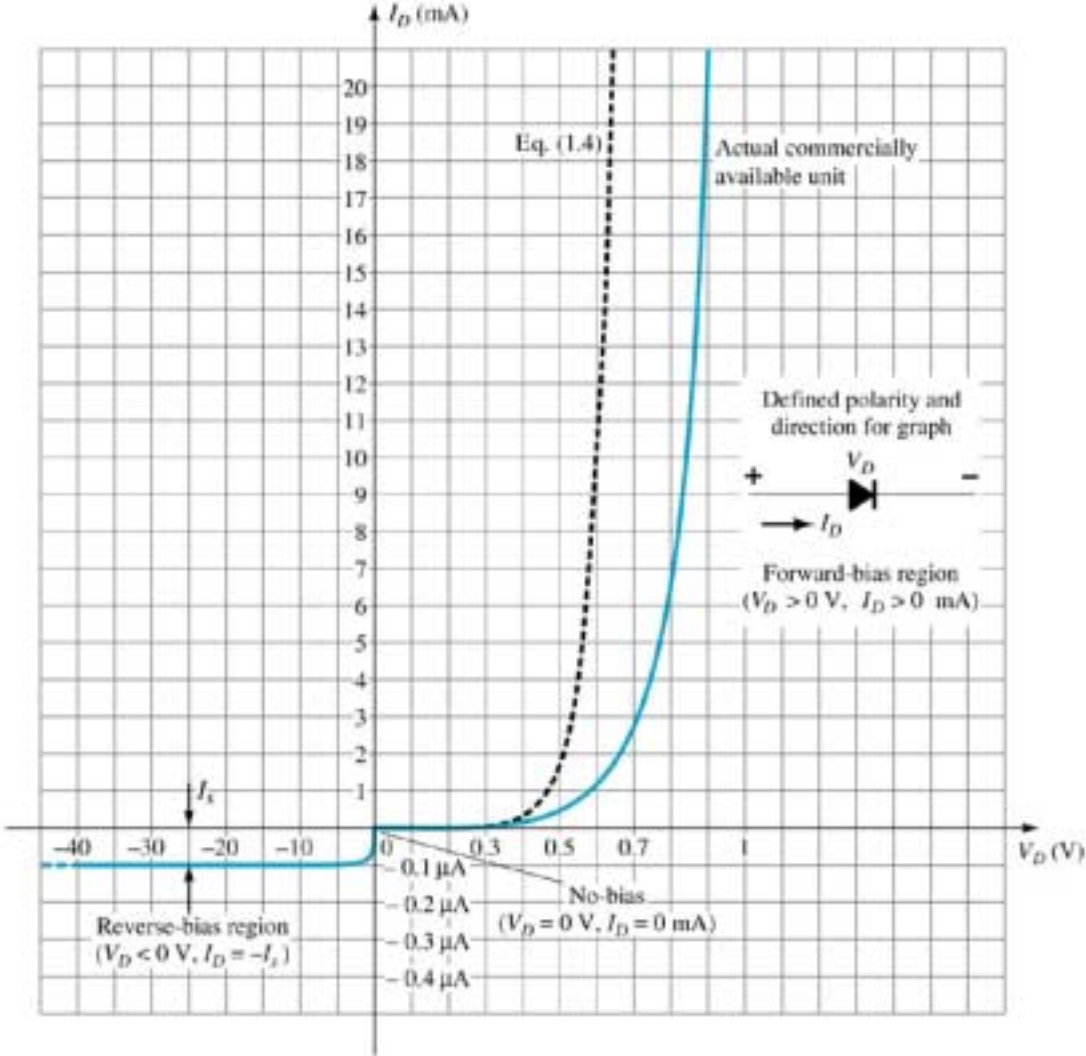

FIGURE 1-21 Forward-bias conditions for a semiconductor diode.

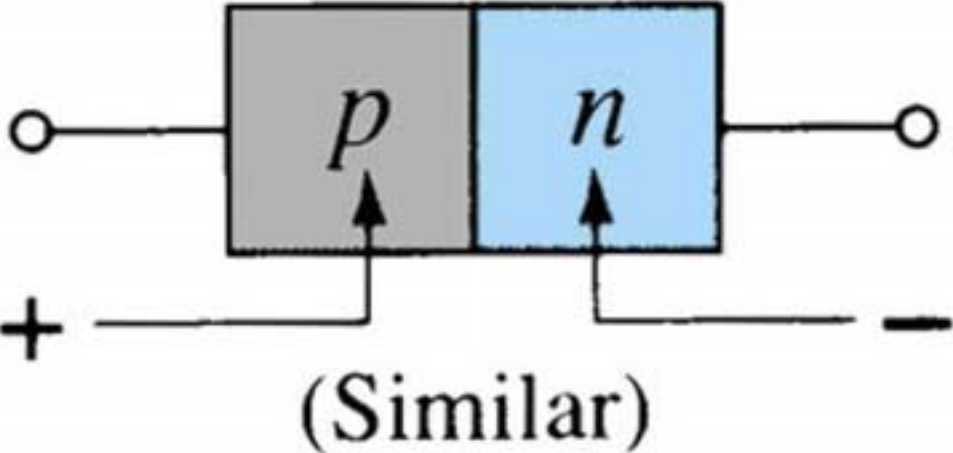
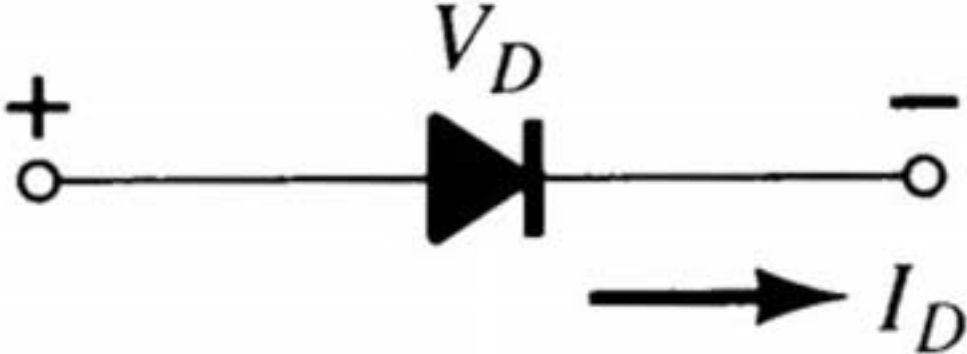

FIGURE 1-22 Zener region.

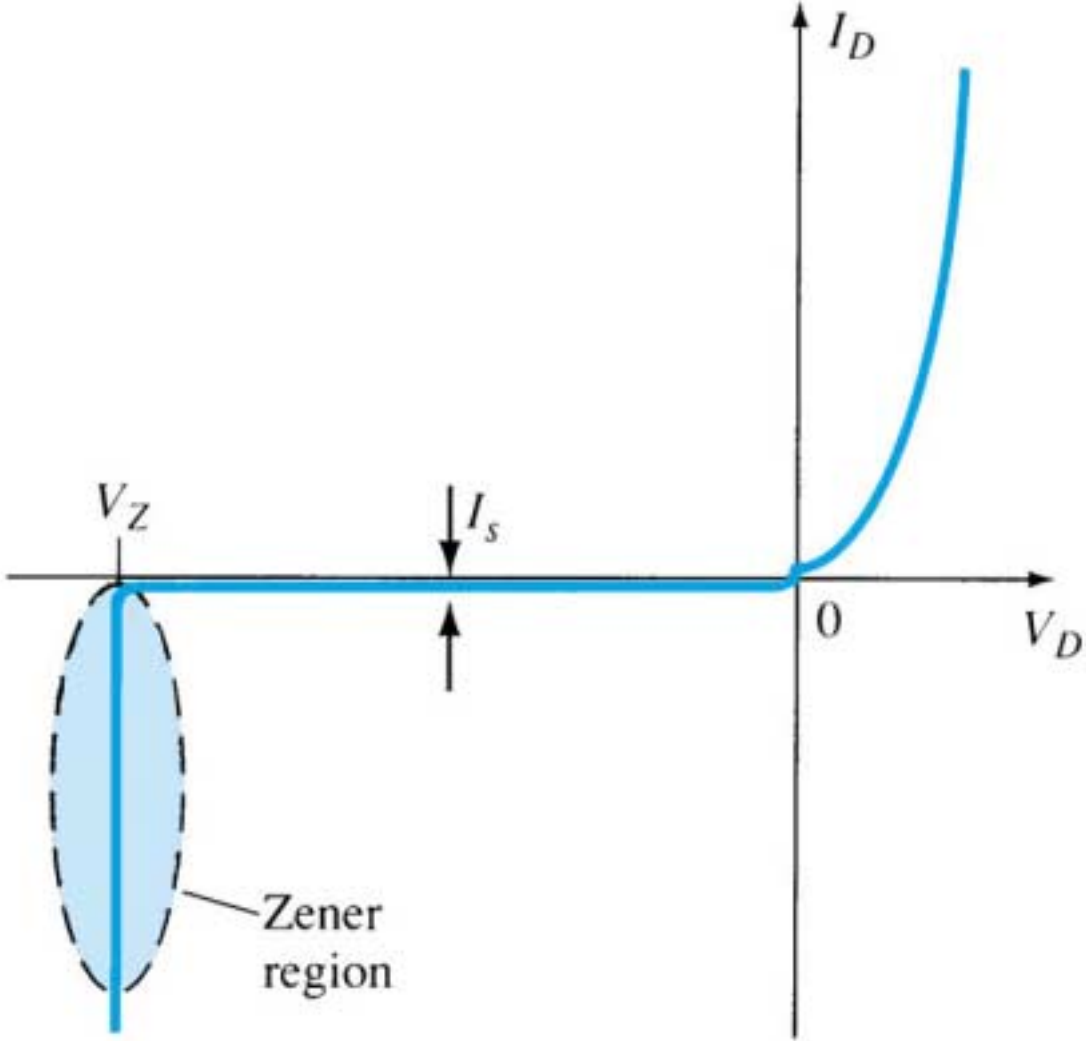

FIGURE 1-23 Comparison of Si and Ge semiconductor diodes.

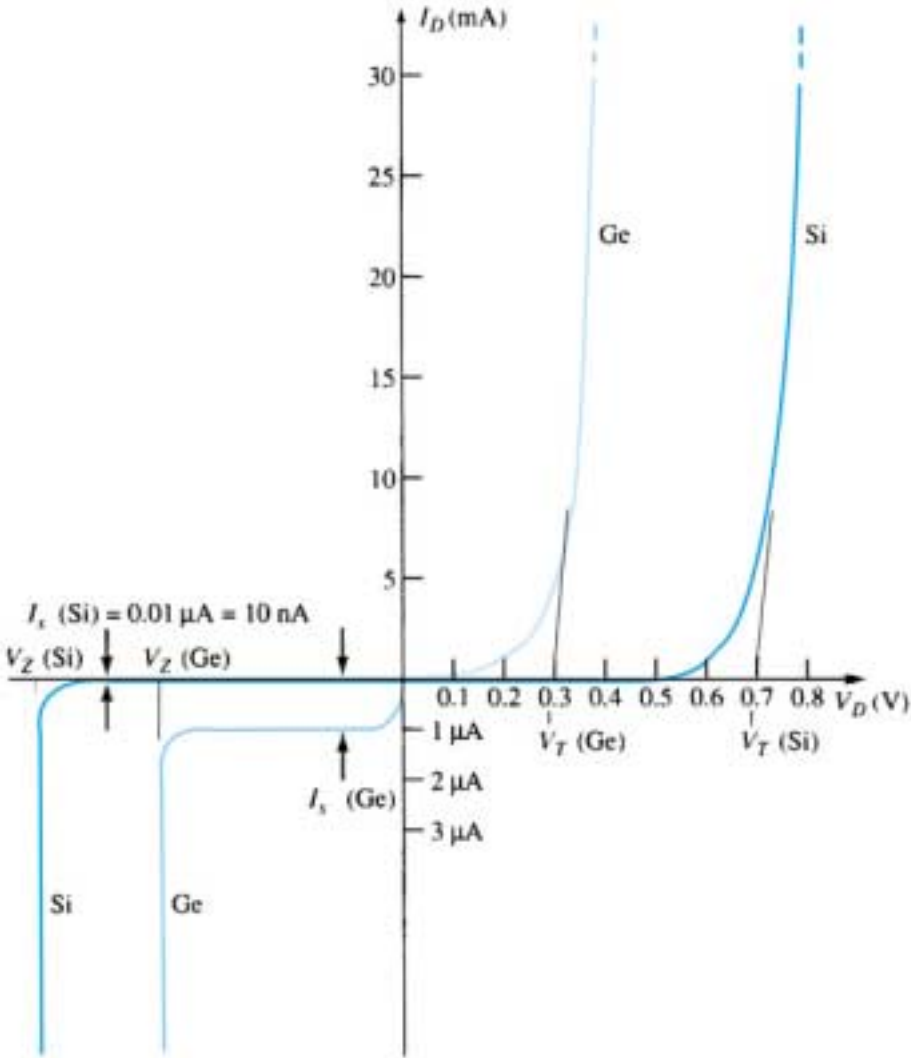

FIGURE 1-24 Variation in diode characteristics with temperature change.

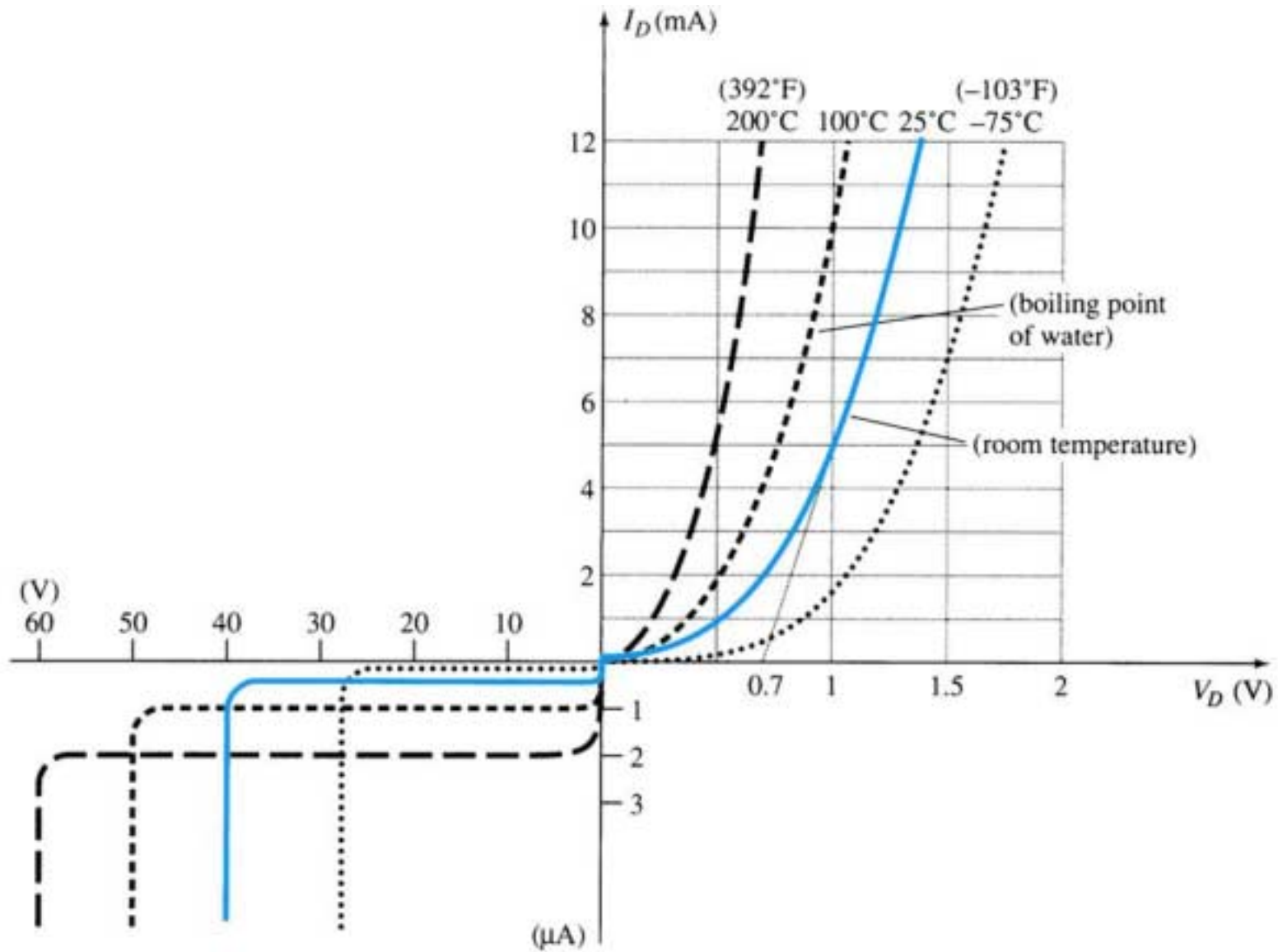

FIGURE 1-30 Determining the dc resistance of a diode at a particular operating point.

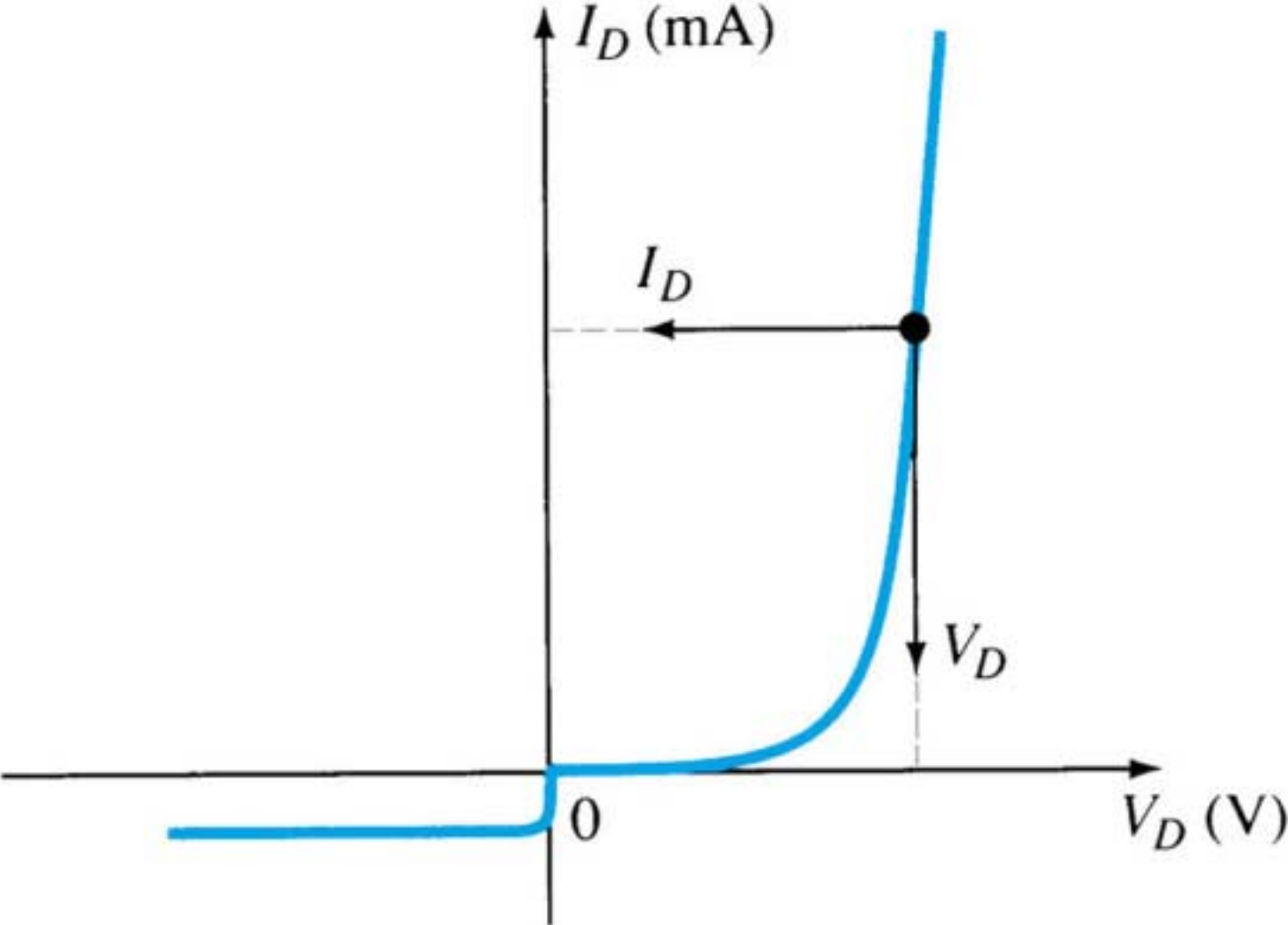

FIGURE 1-31 Example 1.1.

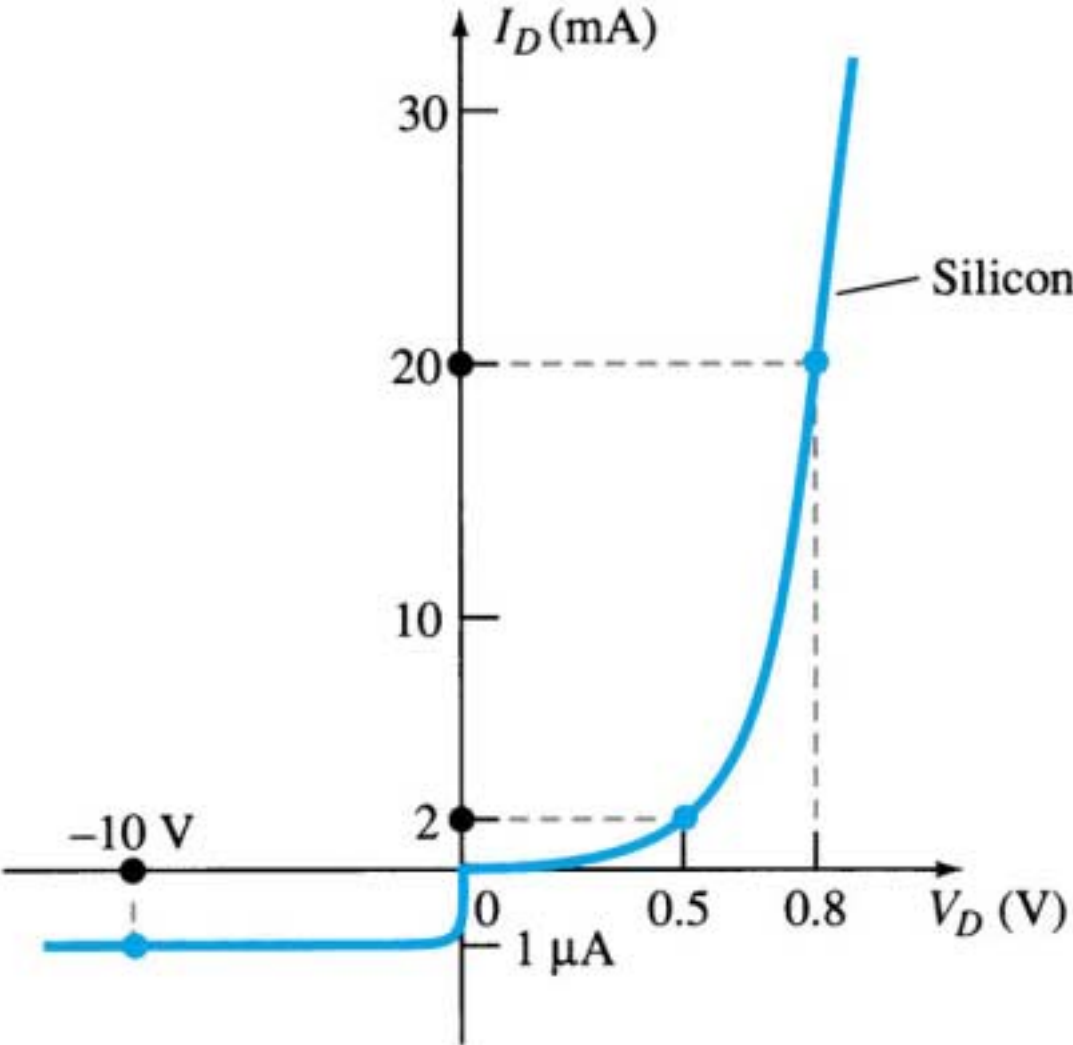

FIGURE 1-32 Defining the dynamic or ac resistance.

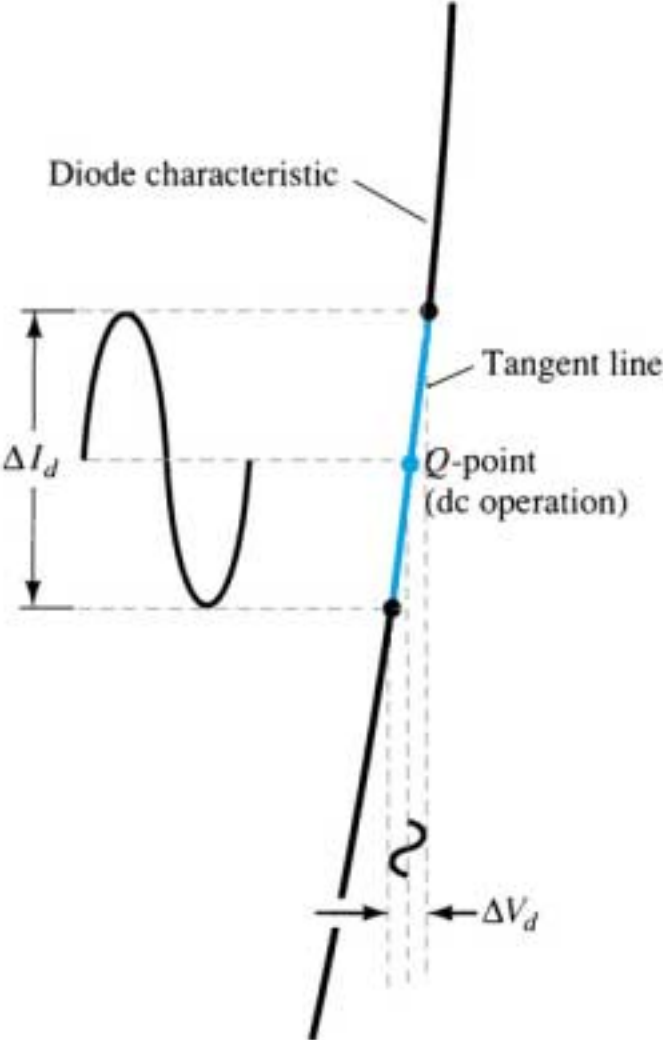

FIGURE 1-33 Determining the ac resistance at a Q -point.

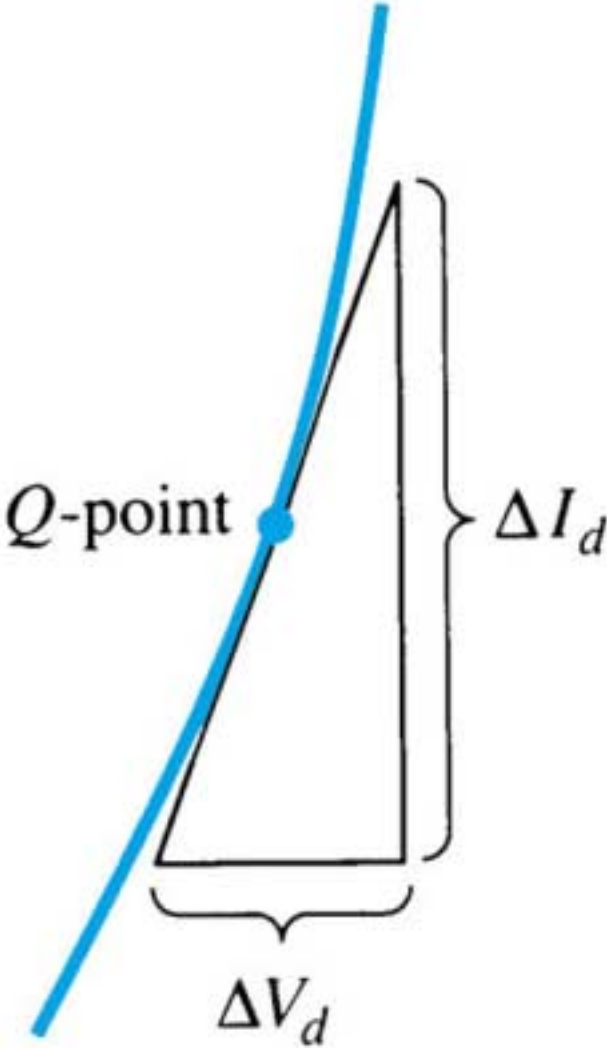

FIGURE 1-34 Example 1.2.

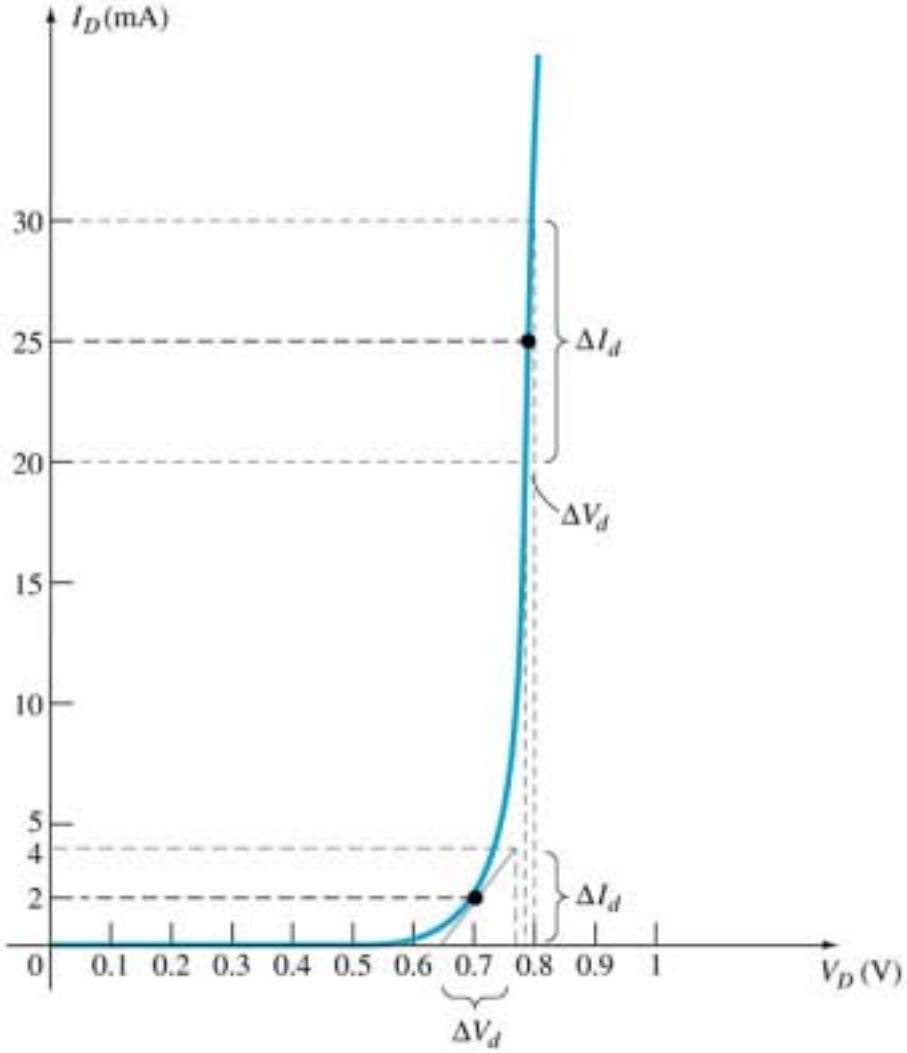

FIGURE 1-35 Determining the average ac resistance between indicated limits.

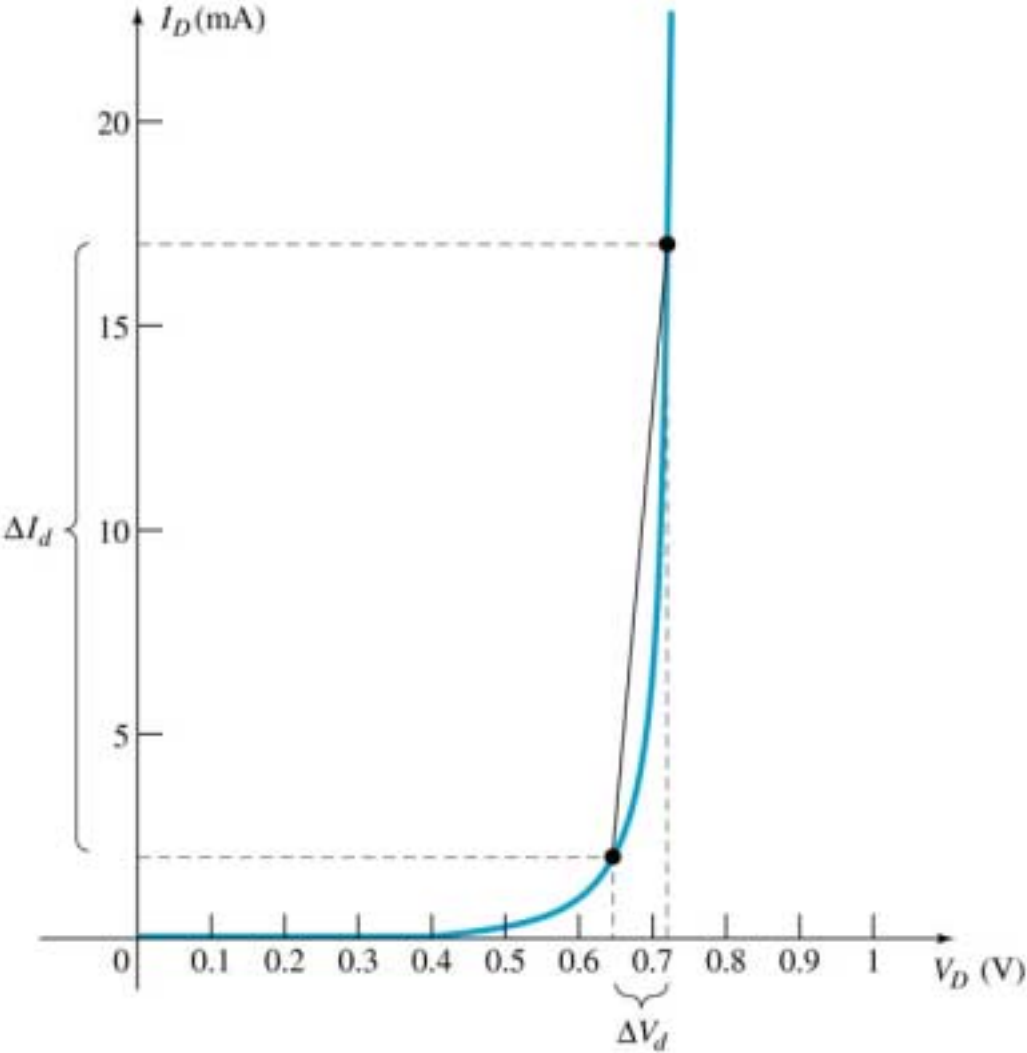

FIGURE 1-36 Defining the piecewise-linear equivalent circuit using straight-line segments to approximate the characteristic curve.

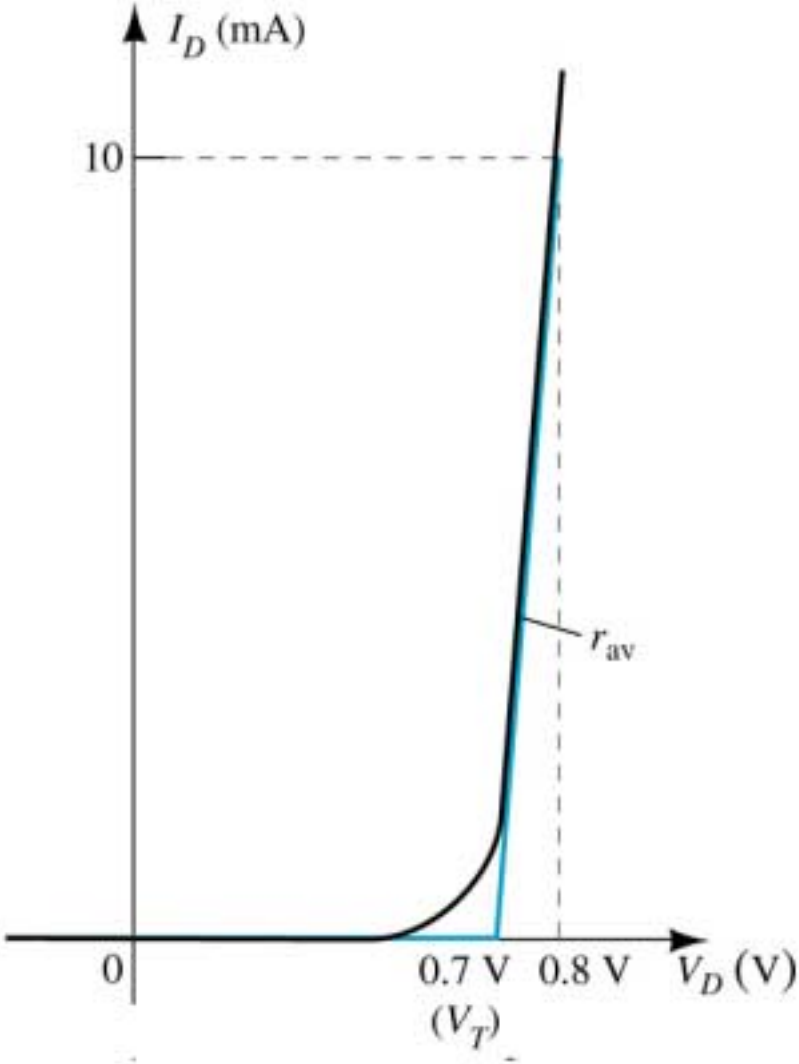

FIGURE 1-37 Components of the piecewise-linear equivalent circuit.

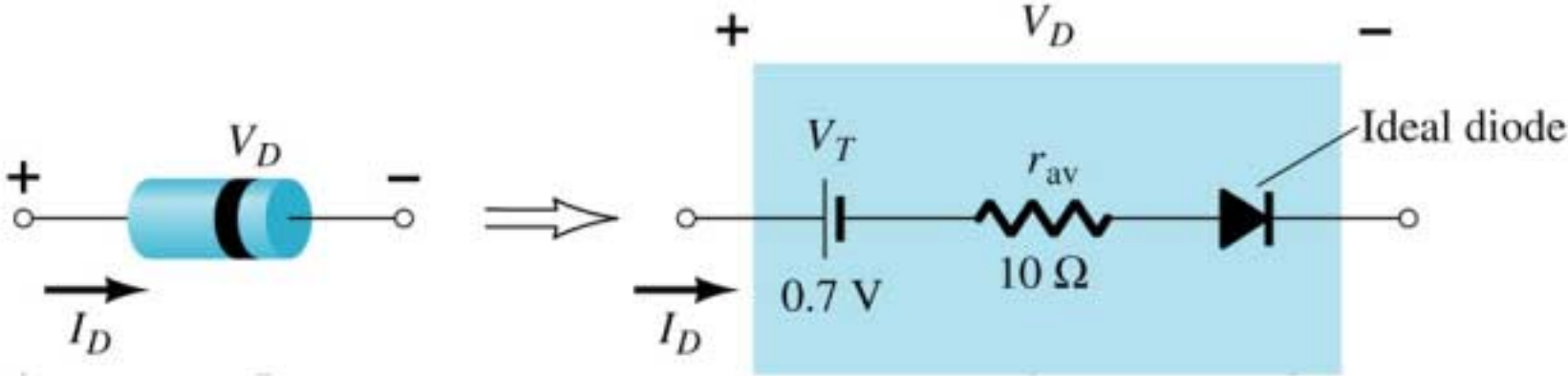

FIGURE 1-38 Simplified equivalent circuit for the silicon semiconductor diode.

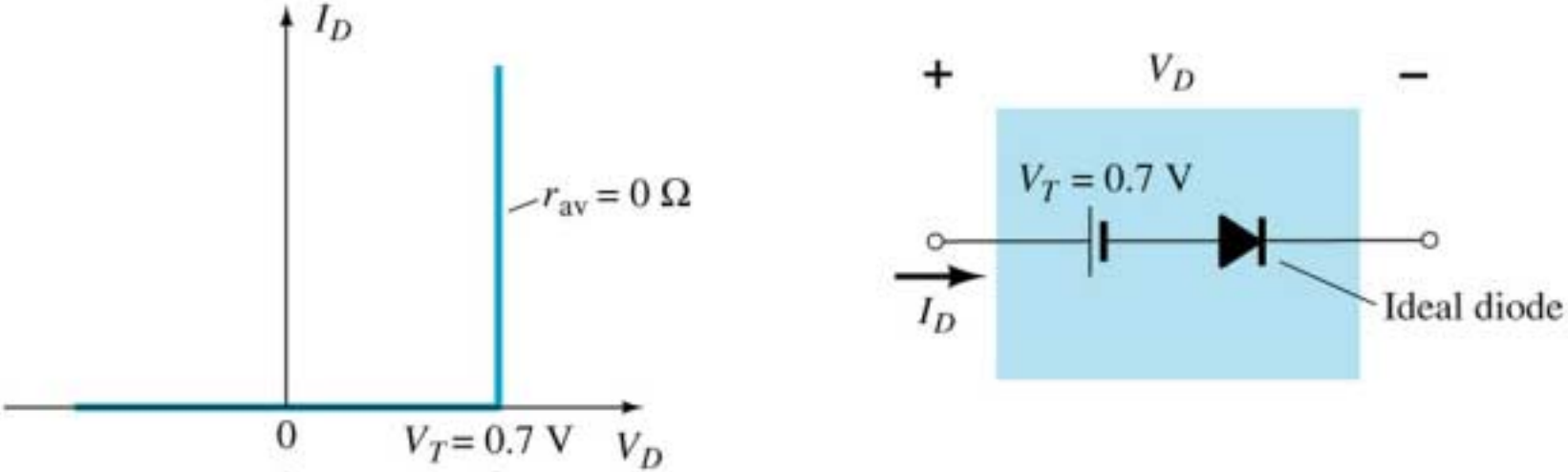

FIGURE 1-39 Ideal diode and its characteristics.

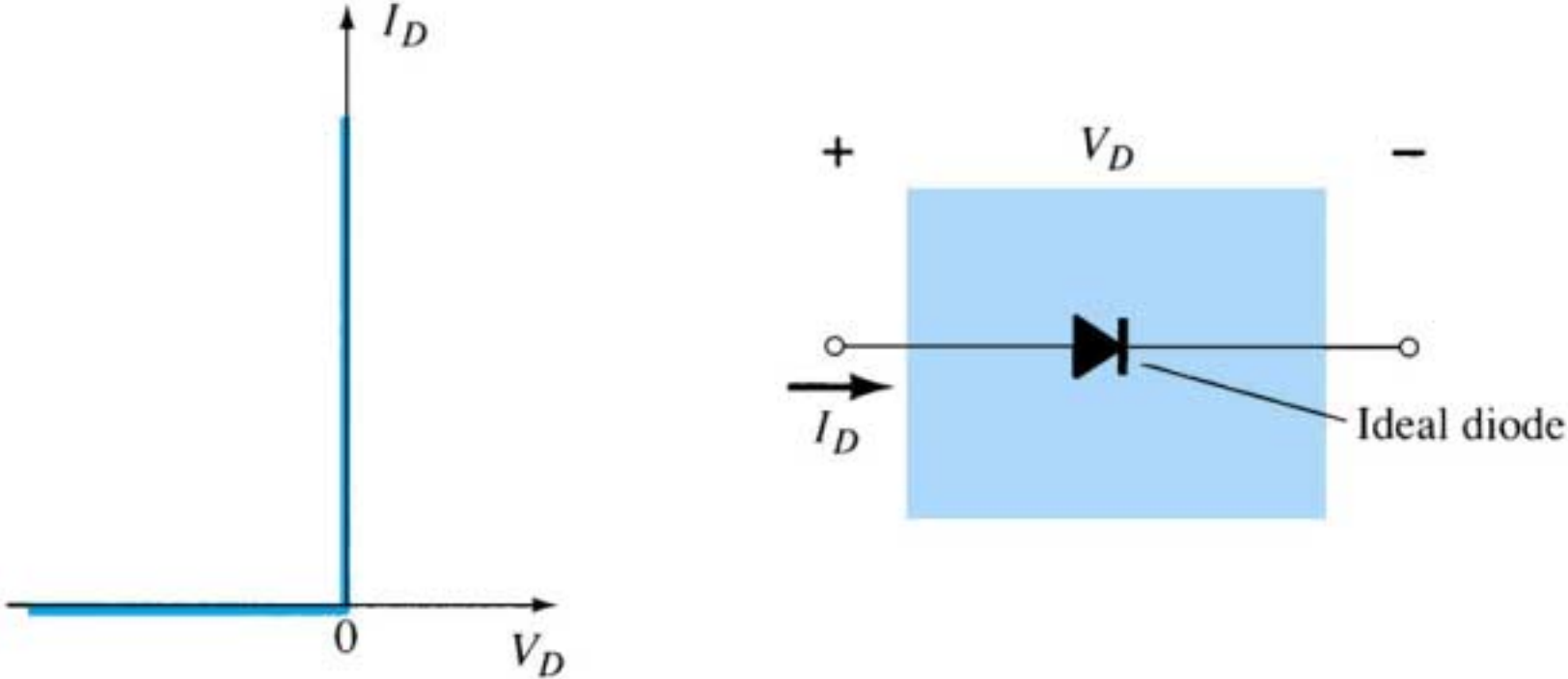

FIGURE 1-52 Reviewing the Zener region.

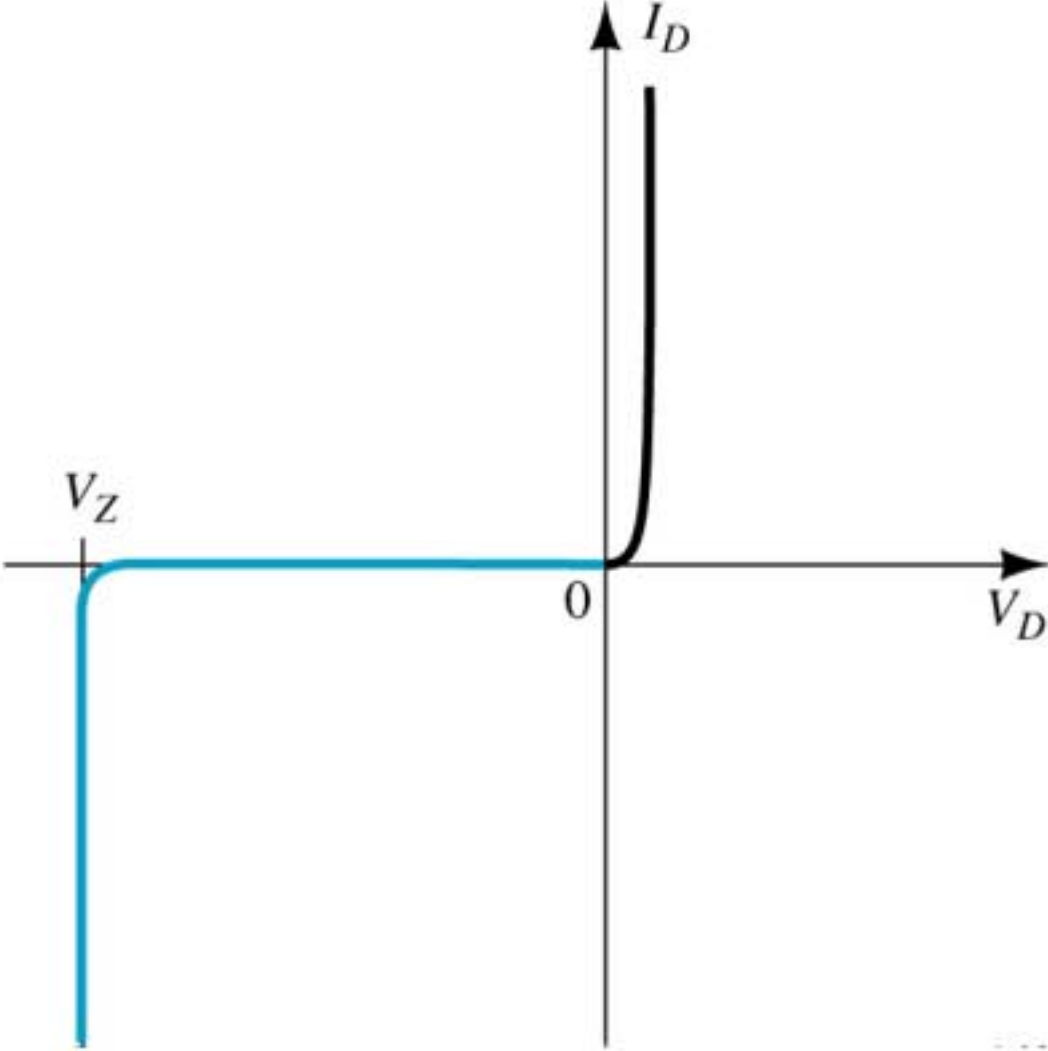

FIGURE 1-53 Conduction direction: (a) Zener diode; (b) semiconductor diode.

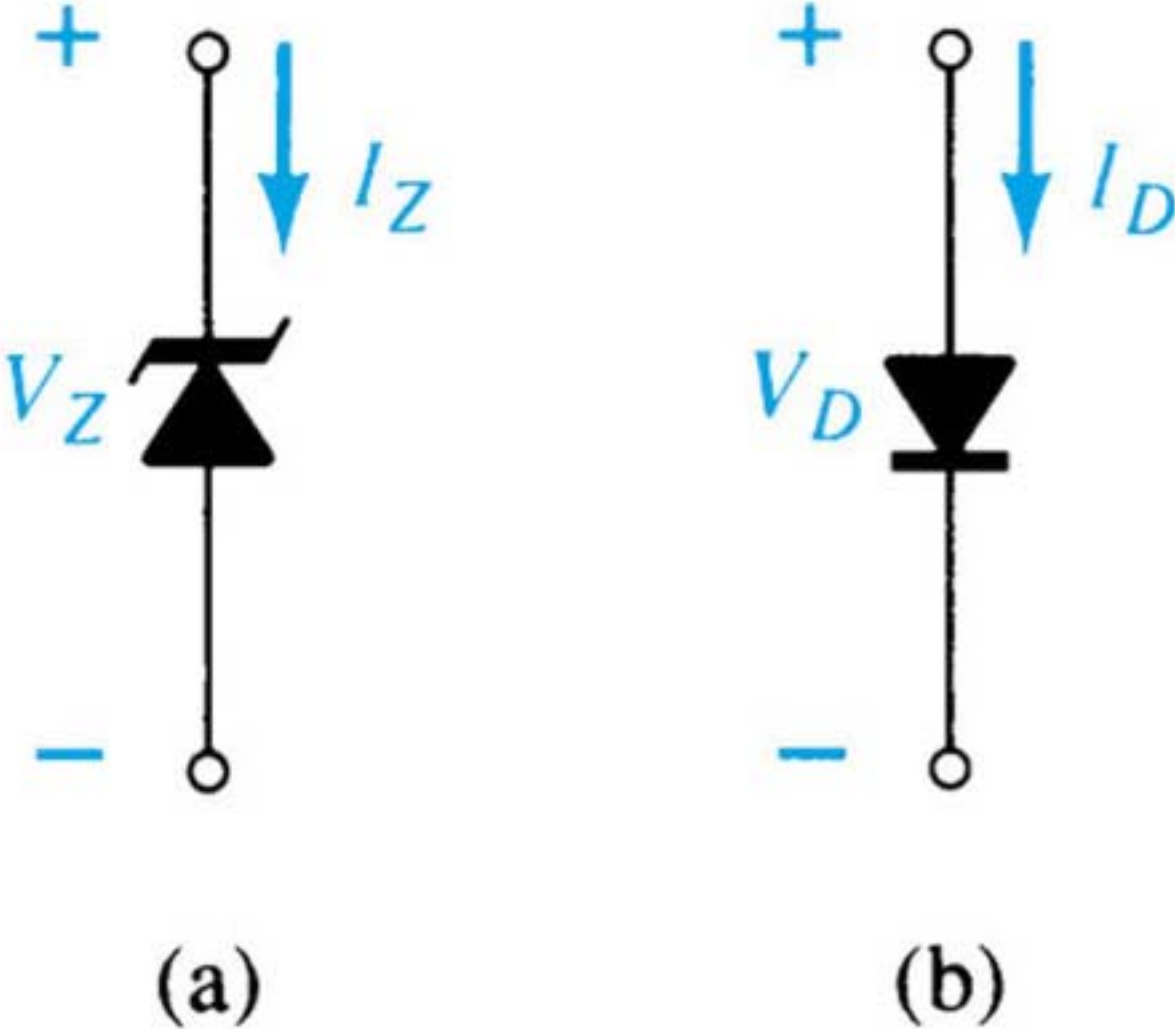

FIGURE 1-54 Zener equivalent circuit: (a) complete; (b) approximate.

